

**DEPARTMENT OF MECHANICAL
ENGINEERING
LAB MANUAL**

SUBJECT: EDC & ADC

B.TECH- 3rd Semester BRANCH: - EE



**KCT COLLEGE OF ENGG & TECH,
FATEHGARH**

Punjab Technical University

LIST OF EXPERIMENTS

Sr. No.	EXPERIMENTS	Date Of Performance	Date Of Submission.	Teacher's Signature
1.	To construct a zener diode voltage regulator.			
2.	Study of Half Wave rectifier.			
3.	To find the Ripple factor and regulation of a Full-wave Rectifier with and without filter.			
4.	To calculate the ripple factor of a bridge rectifier, with and without filters.			
5.	To draw the input and output characteristics of transistor connected in CE configuration.			
6.	To study the response of the RC phase shift oscillator & to determine frequency of oscillation.			
7.	To study and calculate frequency of oscillations of Hartley oscillator. Compare the frequency of oscillations, theoretically and practically.			
8.	To study and calculate frequency of oscillations of colpitt's oscillator.			
9.	To study response of. Wein Bridge Oscillator and determine frequency			

Experiment no 1

Aim

To construct a zener diode voltage regulator.

Apparatus

Zener diode, resistor, variable DC power supply, milliammeter, voltmeter, Rheostat, wire.

Theory

The Zener diode is like a general-purpose signal diode. When biased in the forward direction it behaves just like a normal signal diode, but when a reverse voltage is applied to it, the voltage remains constant for a wide range of currents.

Avalanche Breakdown: There is a limit for the reverse voltage. Reverse voltage can increase until the diode breakdown voltage reaches. This point is called Avalanche Breakdown region. At this stage maximum current will flow through the zener diode. This breakdown point is referred as "Zener voltage".

The Zener Diode is used in its "reverse bias". From the I-V Characteristics curve we can study that the zener diode has a region in its reverse bias characteristics of almost a constant negative voltage regardless of the value of the current flowing through the diode and remains nearly constant even with large changes in current as long as the zener diodes current remains between the breakdown current $I_{Z(\min)}$ and the maximum current rating $I_{Z(\max)}$.

This ability to control itself can be used to great effect to regulate or stabilise a voltage source against supply or load variations. The fact that the voltage across the diode in the breakdown region is almost constant turns out to be an important application of the zener diode as a voltage regulator

Characteristics

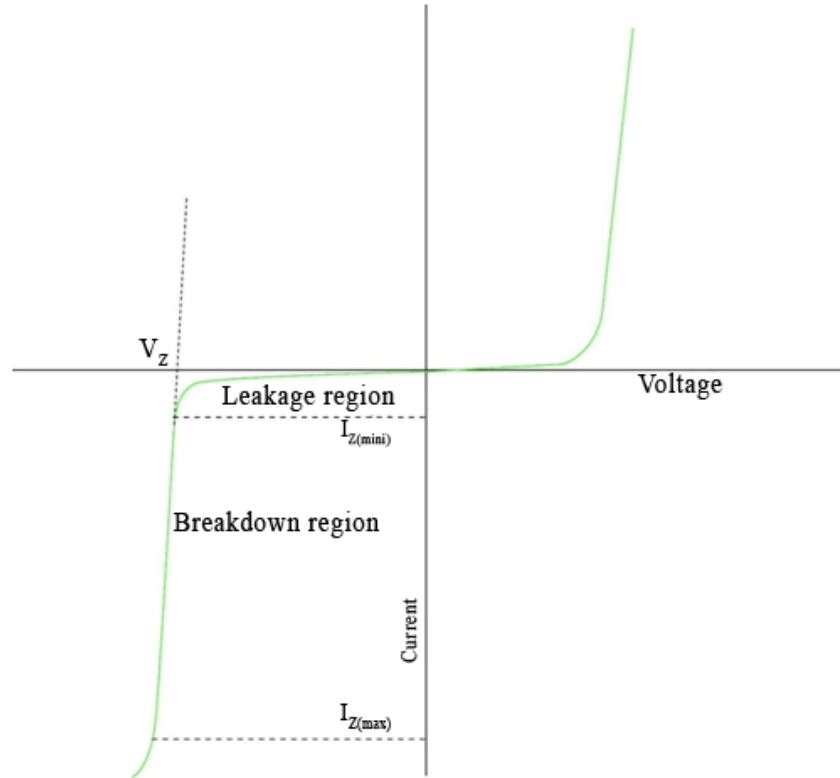

Zener diode characteristic curve

The forward bias region of a Zener diode is identical to that of a regular diode. The typical forward voltage at room temperature with a current of around 1 mA is around 0.6 volts. In the reverse bias condition the Zener diode is an open circuit and only a small leakage current is flowing as shown on the exaggerated plot. As the breakdown voltage is approached the current will begin to avalanche. The initial transition from leakage to breakdown is soft but then the current rapidly increases as shown on the plot. The voltage across the Zener diode in the breakdown region is very nearly constant with only a small increase in voltage with increasing current. At some high current level the power dissipation of the diode becomes excessive and the part is destroyed. There is a minimum Zener current, $I_{Z(\text{min})}$, that places the operating point in the desired breakdown. There is a maximum Zener current, $I_{Z(\text{max})}$, at which the power dissipation drives the junction temperature to the maximum allowed. Beyond that current the diode can be damaged.

P_z . From Watt's law the maximum current is $I_{Z(max)} = P_z / V_z$. Zener diodes are typically available with power ratings of 0.25, 0.4, 0.5, 1, 2, 3, and 5 watts although other values are available.

Zener Diode as Voltage Regulators

The function of a regulator is to provide a constant output voltage to a load connected in parallel with it in spite of the ripples in the supply voltage or the variation in the load current and the zener diode will continue to regulate the voltage until the diodes current falls below the minimum $I_{Z(min)}$ value in the reverse breakdown region. It permits current to flow in the forward direction as normal, but will also allow it to flow in the reverse direction when the voltage is above a certain value - the breakdown voltage known as the Zener voltage. The Zener diode specially made to have a reverse voltage breakdown at a specific voltage. Its characteristics are otherwise very similar to common diodes. In breakdown the voltage across the Zener diode is close to constant over a wide range of currents thus making it useful as a shunt voltage regulator.

The purpose of a voltage regulator is to maintain a constant voltage across a load regardless of variations in the applied input voltage and variations in the load current. A typical Zener diode shunt regulator is shown in Figure 3. The resistor is selected so that when the input voltage is at $V_{IN(min)}$ and the load current is at $I_{L(max)}$ that the current through the Zener diode is at least $I_{Z(min)}$. Then for all other combinations of input voltage and load current the Zener diode conducts the excess current thus maintaining a constant voltage across the load. The Zener conducts the least current when the load current is the highest and it conducts the most current when the load current is the lowest.

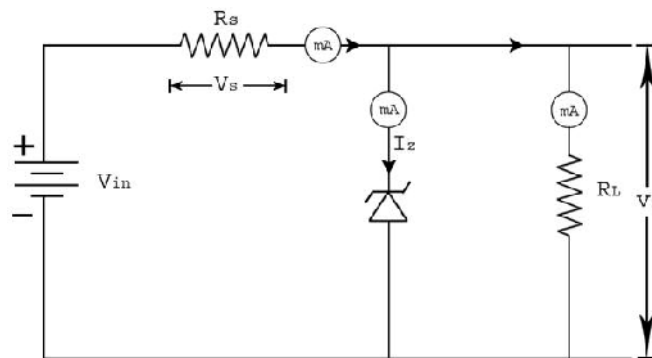

Zener diode shunt regulator

If there is no load resistance, shunt regulators can be used to dissipate total power through the series resistance and the Zener diode. Shunt regulators have an inherent current limiting advantage under load fault conditions because the series resistor limits excess current.

Experiment no. 2

AIM: - *Study of Half Wave rectifier.*

APPARATUS:-

Experimental Board
Multimeters -2No's.
Transformer (6-0-6).
Diode, 1N 4007
Capacitor 100 μ f.
Resistor 1K Ω .
Connecting wires

THEORY: -

During positive half-cycle of the input voltage, the diode D1 is in forward bias and conducts through the load resistor R1. Hence the current produces an output voltage across the load resistor R1, which has the same shape as the +ve half cycle of the input voltage.

During the negative half-cycle of the input voltage, the diode is reverse biased and there is no current through the circuit. i.e, the voltage across R1 is zero. The net result is that only the +ve half cycle of the input voltage appears across the load. The average value of the half wave rectified o/p voltage is the value measured on dc voltmeter.

For practical circuits, transformer coupling is usually provided for two reasons.

1. The voltage can be stepped-up or stepped-down, as needed.
2. The ac source is electrically isolated from the rectifier. Thus preventing shock hazards in the secondary circuit.

CIRCUIT DIAGRAM:-

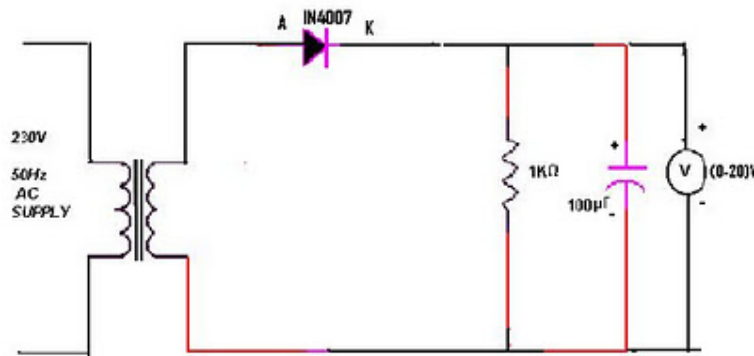

PROCEDURE:-

1. Connections are made as per the circuit diagram.
2. Connect the primary side of the transformer to ac mains and the secondary side to the rectifier input.
3. By the multimeter, measure the ac input voltage of the rectifier and, ac and dc voltage at the output of the rectifier.
4. Find the theoretical of dc voltage by using the formula,

$$V_{dc} = V_m / \pi$$

Where, $V_m = 2V_{rms}$, (V_{rms} =output ac voltage.)

The Ripple factor is calculated by using the formula

$$r = \text{ac output voltage} / \text{dc output voltage.}$$

REGULATION CHARACTERISTICS:-

1. Connections are made as per the circuit diagram.
2. By increasing the value of the rheostat, the voltage across the load and current flowing through the load are measured.
3. The reading is tabulated.
4. Draw a graph between load voltage (V_L) and load current (I_L) taking V_L on X-axis and I_L on y-axis
5. From the value of no-load voltages, the %regulation is calculated using the formula,

Theoretical calculations for Ripple factor:-

Without Filter:-

$$V_{rms} = V_m / 2$$

$$V_m = 2V_{rms}$$

$$V_{dc} = V_m / \pi$$

$$\text{Ripple factor } r = \sqrt{(V_{rms} / V_{dc})^2 - 1} = 1.21$$

With Filter:-

$$\text{Ripple factor, } r = 1 / (2\sqrt{3} f C R)$$

$$\text{Where } f = 50\text{Hz}$$

$$C = 100\mu\text{F}$$

$$R_L = 1\text{K}\Omega$$

PRACTICAL CALCULATIONS:-

$$V_{ac} =$$

$$V_{dc} =$$

$$\text{Ripple factor with out Filter} =$$

$$\text{Ripple factor with Filter} =$$

OBSERVATIONS:-

WITHOUT FILTER

USING DMM	$V_{ac}(v)$	$V_{dc}(v)$	$r = V_{ac} / V_{dc}$

WITH FILTER

USING DMM	$V_{ac}(v)$	$V_{dc}(v)$	$r = V_{ac} / V_{dc}$

--	--	--	--

WITHOUTFILTER:-

$$V_{dc} = V_m / \pi, \quad V_{rms} = V_m / 2, \quad V_{ac} = \sqrt{(V_{rms}^2 - V_{dc}^2)}$$

	$V_m(v)$	$V_{ac}(v)$	$V_{dc}(v)$	$r = V_{ac} / V_{dc}$
USING CRO				

WITHFILTER

	$V_1(V)$	$V_2(V)$	$V_{dc} = (V_1 + V_2) / 2$	$V_{ac} = (V_1 - V_2) / 2 \cdot 3$	$r = V_{ac} / V_{dc}$
USINGCRO					

PRECAUTIONS:

1. The primary and secondary sides of the transformer should be carefully identified.
2. The polarities of the diode should be carefully identified.
3. While determining the % regulation, first Full load should be applied and then it should be decremented in steps.

RESULT:-

1. The Ripple factor for the Half-Wave Rectifier with and without filters is measured.
2. The % regulation of the Half-Wave rectifier is calculated.

Experiment no. 3

AIM:-To find the Ripple factor and regulation of a Full-wave Rectifier with and without filter.

APPARATUS:-

Experimental Board

Transformer (6-0-6v).

P-n Diodes, (IN4007) ---2 No's

Multimeters -2No's

Filter Capacitor (100 μ F/25v) -

Connecting Wires

Load resistor, 1K Ω

THEORY:-

The circuit of a center-tapped full wave rectifier uses two diodes D1&D2. During positive half cycle of secondary voltage (input voltage), the diode D1 is forward biased and D2is reverse biased.

The diode D1 conducts and current flows through load resistor R_L . During negative half cycle, diode

D2 becomes forward biased and D1 reverse biased. Now, D2 conducts and current flows through the load resistor R_L in the same direction. There is a continuous current flow through the load resistor R_L , during both the half cycles and will get unidirectional current as show in the model graph. The difference between full wave and half wave rectification is that a full wave rectifier allows unidirectional (one way) current to the load during the entire 360 degrees of the input signal and half-wave rectifier allows this only during one half cycle (180 degree).

CIRCUIT DIAGRAM:-

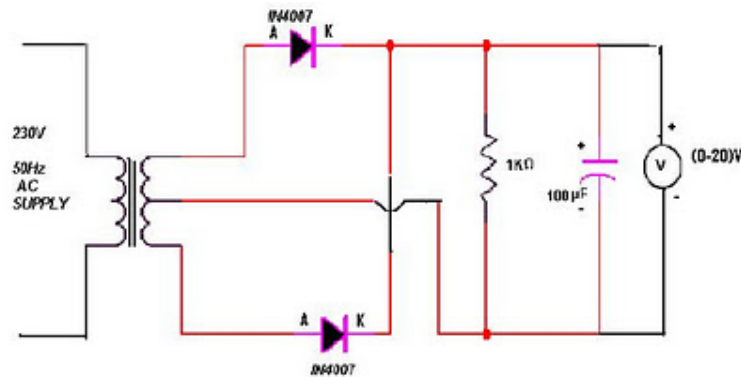

PROCEDURE:

1. Connections are made as per the circuit diagram.
2. Connect the ac mains to the primary side of the transformer and the secondary side to the rectifier.
3. Measure the ac voltage at the input side of the rectifier.
4. Measure both ac and dc voltages at the output side the rectifier.
5. Find the theoretical value of the dc voltage by using the formula $V_{dc} = 2V_m / \pi$
6. Connect the filter capacitor across the load resistor and measure the values of V_{ac} and V_{dc} at the output.
7. The theoretical values of Ripple factors with and without capacitor are calculated.
8. From the values of V_{ac} and V_{dc} practical values of Ripple factors are calculated. The practical values are compared with theoretical values.

THEORITICAL CALCULATIONS:-

$$V_{rms} = V_m / \sqrt{2}$$

$$V_m = V_{rms} \sqrt{2}$$

$$V_{dc} = 2V_m / \pi$$

(i) Without filter:

$$\text{Ripple factor, } r = \sqrt{(V_{rms} / V_{dc})^2 - 1} = 0.482$$

(ii)With filter:

$$\text{Ripple factor, } r = 1 / (4\sqrt{3} f C R_L) \quad \text{where } f = 50\text{Hz}$$
$$C = 100\mu\text{F}$$
$$R_L = 1\text{K}\Omega$$

PRACTICAL CALCULATIONS:

Without filter:-

$$V_{ac} =$$

$$V_{dc} =$$

$$\text{Ripple factor, } r = V_{ac}/V_{dc}$$

With filters:-

$$V_{ac} =$$

$$V_{dc} =$$

$$\text{Ripple factor} = V_{ac}/V_{dc}$$

Without Filter:

USING DMM	$V_{ac}(v)$	$V_{dc}(v)$	$r = V_{ac}/ V_{dc}$

With Filter

USING DMM	$V_{ac}(v)$	$V_{dc}(v)$	$r = V_{ac}/ V_{dc}$

Without Filter

$$V_{rms} = V_m / \sqrt{2} \quad , \quad V_{dc} = 2V_m / \pi \quad , \quad V_{ac} = \sqrt{(V_{rms}^2 - V_{dc}^2)}$$

	$V_m(v)$	$V_{ac}(v)$	$V_{dc}(v)$	$r = V_{ac} / V_{dc}$
USING CRO				

With Filter

	$V_1(V)$	$V_2(V)$	$V_{dc} = (V_1 + V_2) / 2$	$V_{ac} = (V_1 - V_2) / 2 \cdot 3$	$r = V_{ac} / V_{dc}$
USING CRO					

PRECAUTIONS:

1. The primary and secondary side of the transformer should be carefully identified
2. The polarities of all the diodes should be carefully identified.

RESULT:-

The ripple factor of the Full-wave rectifier (with filter and without filter) is calculated.

Experiment no. 4

AIM: - To calculate the ripple factor of a bridge rectifier, with and without filters.

APPARATUS:-

Experimental board
Diodes, IN4007 ---- 4 Nos.
Resistor, $1K\Omega$
Capacitor, $100\mu F/25v$.
Transformer (6-0-6v)
Multi meters –2 No
Connecting Wires

CIRCUIT DIAGRAM:-

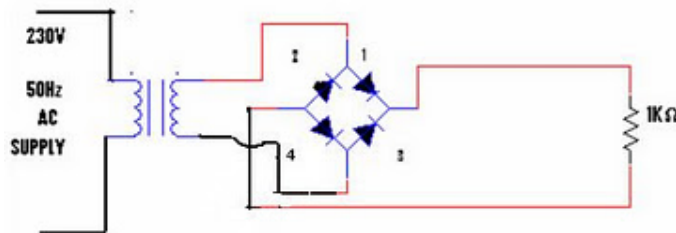

THEORY:-

The bridge rectifier is also a full-wave rectifier in which four p-n diodes are connected in the form of a bridge fashion. The Bridge rectifier has high efficiency when compared to half-wave rectifier. During every half cycle of the input, only two diodes will be conducting while other two diodes are in reverse bias.

PROCEDURE:-

1. Connections are made as per the circuit diagram.
2. Connect the ac main to the primary side of the transformer and secondary side to the bridge rectifier.
3. Measure the ac voltage at the input of the rectifier using the multi meter.
4. Measure both the ac and dc voltages at the output of the Bridge rectifier.

5. Find the theoretical value of dc voltage by using the formula,

CALCULATIONS:-

Theoretical calculations:-

$$V_{rms} = V_m / \sqrt{2}$$

$$V_m = V_{rms} \sqrt{2}$$

$$V_{dc} = 2V_m / \pi$$

MODELWAVEFORM:-

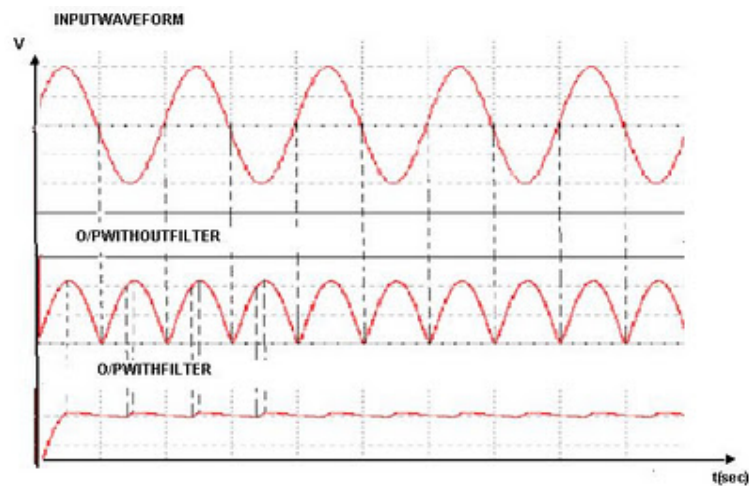

PRECAUTIONS:-

1. The voltage applied should not exceed in the ratings of the diode
2. The diodes will be connected correctly

RESULT:-

The Ripple factor of Bridge rectifier is with and without filter calculated.

Experiment no. 5

AIM: . To draw the input and output characteristics of transistor connected in CE configuration

APPARATUS:

Transistor (BC 107)
R.P.S (0-30V) 2Nos
Voltmeters (0-20V) 2Nos
Ammeters (0-200 μ A)
(0-500mA)
Resistors 1Kohm
Bread board

THEORY:

A transistor is a three terminal device. The terminals are emitter, base, collector. In common emitter configuration, input voltage is applied between base and emitter terminals and out put is taken across the collector and emitter terminals. Therefore the emitter terminal is common to both input and output.

The input characteristics resemble that of a forward biased diode curve. This is expected since the Base-Emitter junction of the transistor is forward biased. As compared to CB arrangement I_B increases less rapidly with V_{BE} . Therefore input resistance of CE circuit is higher than that of CB circuit.

The output characteristics are drawn between I_C and V_{CE} at constant I_B , the collector current varies with V_{CE} upto few volts only. After this the collector current becomes almost constant, and independent of V_{CE} . The value of V_{CE} up to which the collector current changes with V_{CE} is known as Knee voltage. The transistor always operated in the region above Knee voltage, I_C is always constant and is approximately equal to I_B .

The current amplification factor of CE configuration is given by

$$B = \Delta I_C / \Delta I_B$$

CIRCUIT DIAGRAM:

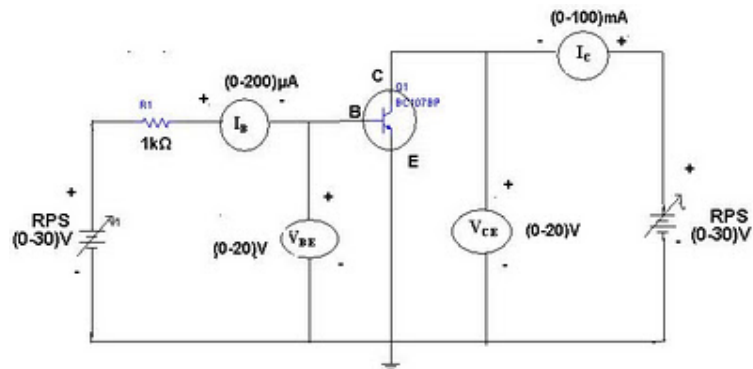

PROCEDURE:

INPUT CHARACTERISTICS:

1. Connect the circuit as per the circuit diagram.
2. For plotting the input characteristics the output voltage V_{CE} is kept constant at 1V and for different values of V_{BE} . Note down the values of I_C
3. Repeat the above step by keeping V_{CE} at 2V and 4V.
4. Tabulate all the readings.
5. plot the graph between V_{BE} and I_B for constant V_{CE}

OUTPUT CHARACTERISTICS:

1. Connect the circuit as per the circuit diagram
2. for plotting the output characteristics the input current I_B is kept constant at 10 μ A and for different values of V_{CE} note down the values of I_C
3. repeat the above step by keeping I_B at 75 μ A 100 μ A
4. tabulate the all the readings
5. plot the graph between V_{CE} and I_C for constant I_B

OBSERVATIONS:

INPUT CHARACTERISTICS:

S.NO	$V_{CE} = 1V$		$V_{CE} = 2V$		$V_{CE} = 4V$	
	$V_{BE}(V)$	$I_B(\mu A)$	$V_{BE}(V)$	$I_B(\mu A)$	$V_{BE}(V)$	$I_B(\mu A)$

OUT PUT CHAREACTARISTICS:

S.NO	$I_B = 50 \mu A$		$I_B = 75 \mu A$		$I_B = 100 \mu A$	
	$V_{CE}(V)$	$I_C(mA)$	$V_{CE}(V)$	$I_C(mA)$	$V_{CE}(V)$	$I_C(mA)$

MODEL GRAPHS:

INPUT CHARACTERISTICS:

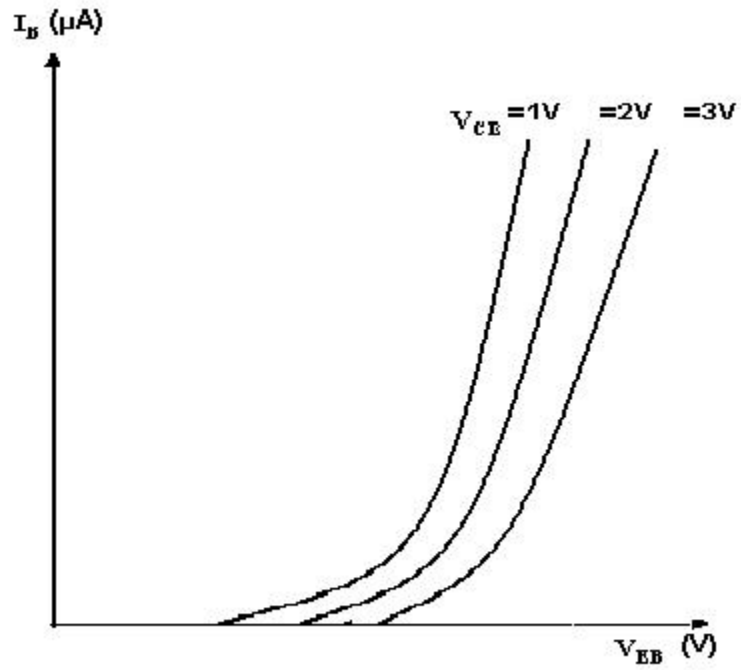

OUTPUT CHARACTERISTICS:

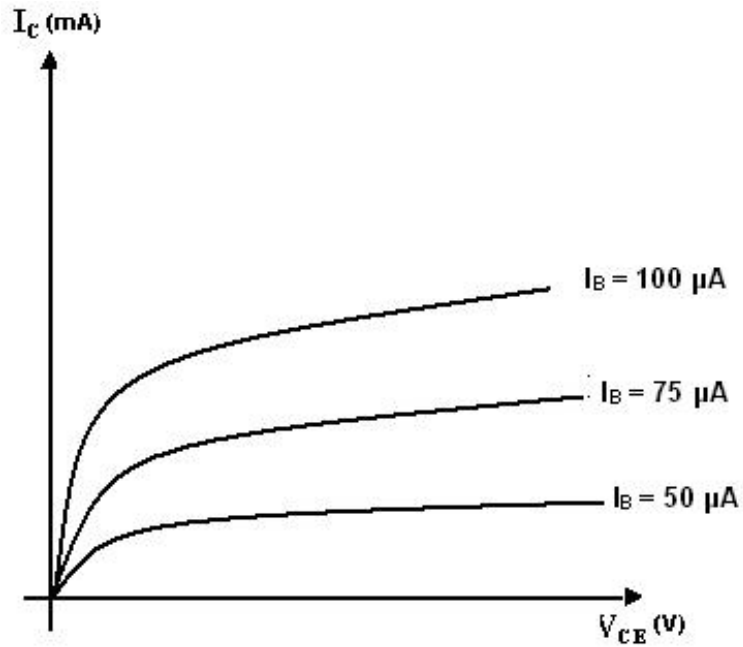

PRECAUTIONS:

1. The supply voltage should not exceed the rating of the transistor
2. Meters should be connected properly according to their polarities

RESULT:

The input and out put characteristics of a transistor in CE configuration are Drawn

Experiment no. 6

AIM: To study the response of the RC phase shift oscillator & to determine frequency of oscillation.

APPARATUS:

1. Transistor BC107

2. Resistors: 10K Ω -3Nos

8K Ω or 10K Ω

22K Ω

1.2K Ω

100K Ω

3. Capacitors: 0.001 μ f - 3 Nos

10 μ F - 2Nos

1 μ f

4. Regulated power Supply

5. CRO

THEORY:

RC-Phase shift Oscillator has a CE amplifier followed by three sections of RC phase shift feed back Networks the out put of the last stage is return to the input of the amplifier. The values of R and C are chosen such that the phase shift of each RC section is 60°. Thus The RC ladder network produces a total phase shift of 180° between its input and output voltage for the given frequencies. Since CE Amplifier produces 180 ° phases shift the total phase shift from the base of the transistor around the circuit and back to the base will be exactly 360° or 0°. This satisfies the Barkhausen condition for sustaining oscillations and total loop gain of this circuit is greater than or equal to 1, this condition used to generate the sinusoidal oscillations. The frequency of oscillations of RC-Phase Shift Oscillator is,

$$f = \frac{1}{2\pi RC \sqrt{6}}$$

CIRCUIT DIAGRAM:

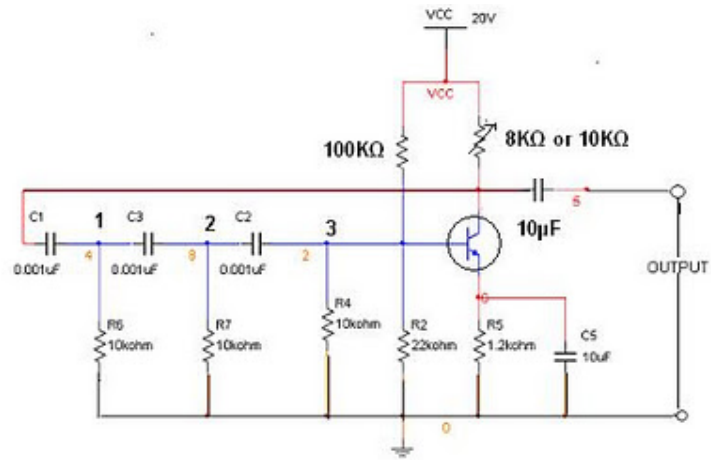

PROCEDURE:

1. Make the connection as per the circuit diagram as shown above.
2. Observe the output signal and note down the output amplitude and time period (T_d).
3. Calculate the frequency of oscillations theoretically and verify it practically ($f=1/T_d$).
4. Calculate the phase shift at each RC section by measuring the time shifts (T_p) between the final waveform and the waveform at that section by using the below formula.

OBSERVATIONS:

THEORITICAL CALCULATIONS: $R = 10K\Omega$, $C = 0.001 \mu f$

$$f = \frac{1}{2\pi RC \cdot \sqrt{6}} =$$

PRACTICAL CALCULATIONS:

$$T_d =$$

$$f = \frac{1}{T_d}$$

$$(1). \theta_1 = \frac{T_{p1}}{T_d} * 360^\circ =$$

$$(2). \theta_2 = \frac{T_{p2}}{T_d} * 360^\circ =$$

$$(3). \theta_3 = \frac{T_{p3}}{T_d} * 360^\circ =$$

MODEL WAVE FORMS:

OUT PUT WAVE FORM :

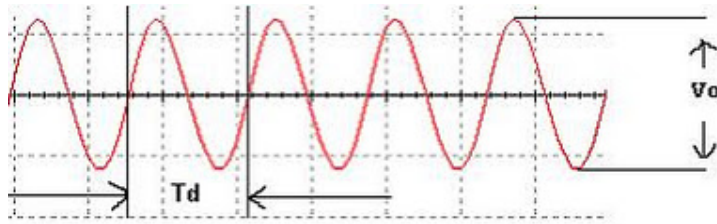

OUT PUT WAVE FORM : $\theta = 60^\circ$

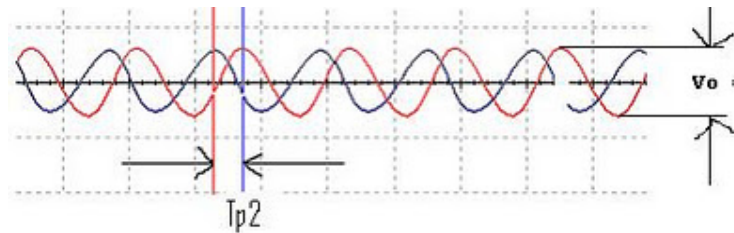

OUT PUT WAVE FORM : $\theta = 120^\circ$

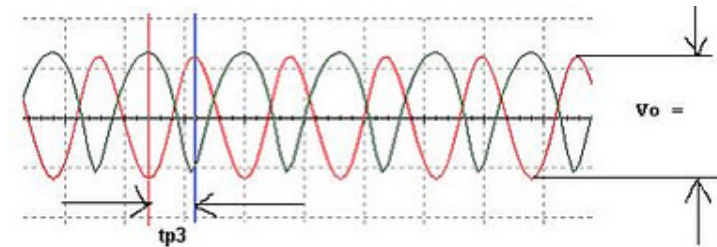

OUT PUT WAVE FORM : $\theta = 180$

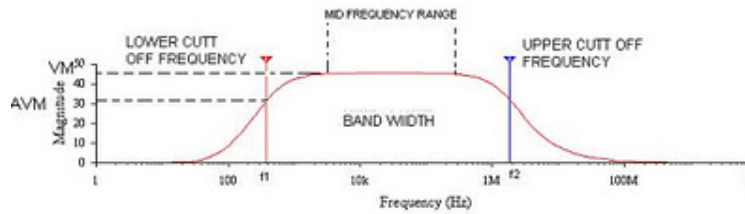

RESULT: The frequency of RC phase shift oscillator is calculated and the phase shift at different RC sections is noted.

Experiment no. 7

AIM: To study and calculate frequency of oscillations of Hartley oscillator. Compare the frequency of oscillations, theoretically and practically.

APPARATUS: Transistor BC 107
Capacitors 0.1 μ F, 10 μ F
Resistors 6.8Kohm, 1Kohm and 100Kohm
Decade inductance box (DIB)
Decade resistance box (DRB)
Cathode ray oscilloscope
Bread board
Regulated power supply (0-30V)
Connecting wires

CIRCUIT DIAGRAM:

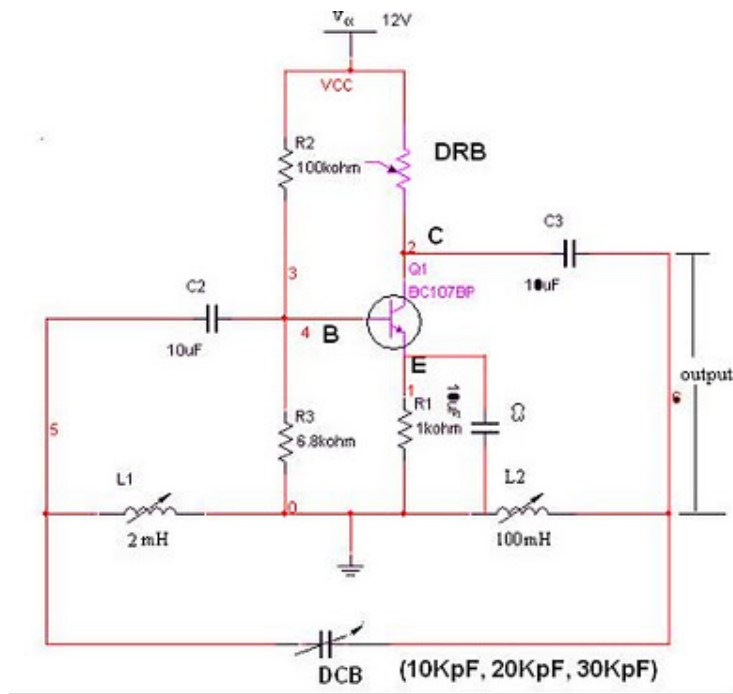

THEORY:

Hartley oscillator is very popular and is commonly used as a local oscillator in radio receivers. It has two main advantages viz... Adaptability to wide range of frequencies and easy to tune. The tank circuit is made up of L1, L2, and C1. The coil L1 is inductively coupled to coil L2, the combination functions as auto transformer. The resistances R2 and R3 provide the necessary biasing. The capacitance C2 blocks the d.c component. The frequency of oscillations is determined by the values of L1, L2 and C1 and is given by,

$$F = \frac{1}{2\pi(C1(\sqrt{L1+L2}))}$$

The energy supplied to the tank circuit is of correct phase. The auto transformer provides 180° out of phase. Also another 180° is produced By the transistor. In this way, energy feedback to the tank circuit is in phase with the generated oscillations.

PROCEDURE:

1. Connections are made as per the circuit diagram.
2. Connect CRO at output terminals and observe wave form.
3. Calculate practically the frequency of oscillations by using the Expression.
 $F=1/T$, Where T= Time period of the waveform
4. Repeat the above steps 2, 3 for different values of L1 and note Down practical values of oscillations of colpitts oscillator.
5. Compare the values of frequency of oscillations both theoretically And Practically.

OBSERVATIONS:

CAPACITANCE(μ F)	Theoretical frequency (KHZ)	Practical frequency (KHZ)

MODEL GRAPH:

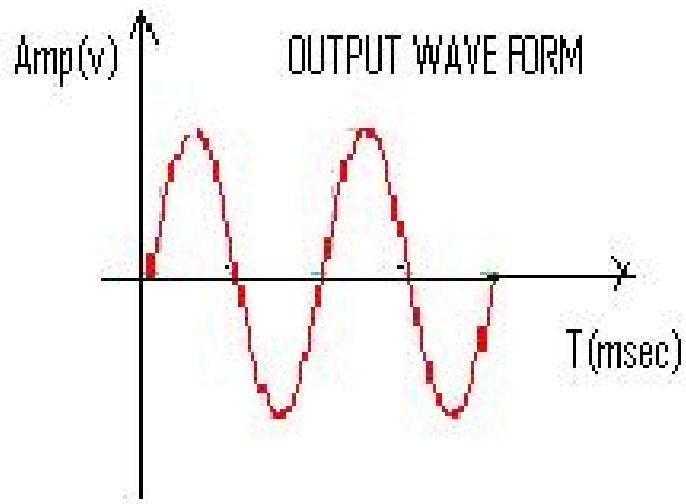

PRECAUTIONS:

1. All the connections should be correct.
2. Transistor terminals must be identified properly.
3. Reading should be taken without any parallax error.

RESULT: Frequency of oscillations is calculated and compared with theoretical values.

Experiment no. 8

AIM: To study and calculate frequency of oscillations of colpitt's oscillator.

APPARATUS: Transistor BC 107

Capacitors $0.1\mu\text{F}$ - 2Nos

$10\mu\text{F}$ - 2Nos

$47\mu\text{F}$ - 1No

Resistors $6.8\text{k}\Omega$, $1\text{k}\Omega$, $100\text{k}\Omega$

Decade Inductance Box (DIB)

Decade Resistance Box (DRB)

Cathode Ray Oscilloscope (CRO)

Regulated Power Supply (0-30V)

Connecting Wires

CIRCUITDIAGRAM:

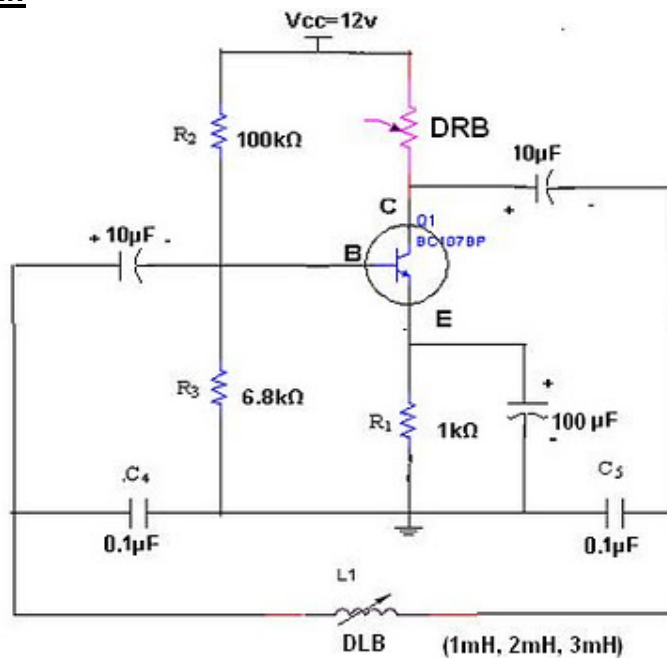

THEORY:

The tank circuit is made up of L_1, C_4 and C_5 . The resistance R_2 and R_3 provides the necessary biasing. The capacitance C_2 blocks the D.C component. The frequency of oscillations is determined by the values of L_1, C_4 and C_5 , and is given by

$$f = 1 / (2\pi (C_T L_1)^{1/2}) \text{ Where } C_T = C_1 C_2 / (C_1 + C_2)$$

The energy supplied to the tank circuit is of correct phase. The tank circuit provides 180° out of phase. Also the transistor provides another 180° . In this way, energy feedback to the tank circuit is in phase with the generated oscillations.

PROCEDURE:

1. connections are made as per circuit diagram.
2. Connect CRO output terminals and observe the waveform.
3. Calculate practically the frequency of oscillations by using the expression
 $f = 1 / T$ ($T =$ Time period of the waveform)
4. Repeat the above steps 2,3 for different values of L , and note down the practically values of oscillations of the collpitt's oscillator.
5. Compare the values of oscillations both theoritically and practically.

OBSERVATIONS:

Inductance (mH)	Theoretical Frequency (Hz)	Practical Frequency (Hz)

MODELWAVEFORM:

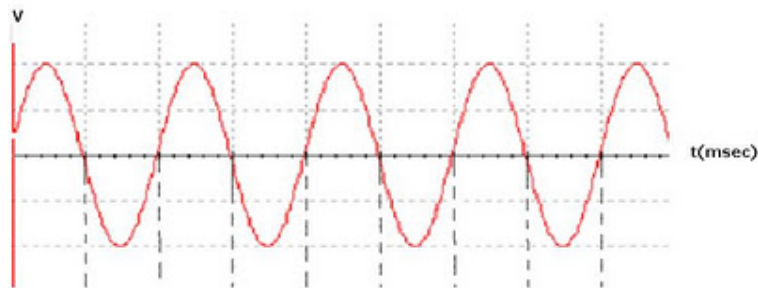

PRECAUTIONS:

1. The connections should be correct.
2. Transistor terminals should be identified properly.
3. Readings should be taken without parallax error.

RESULT: Frequency of oscillations of colpitts oscillator is measured practically and compared

Experiment no.9

AIM: To study response of. Wein Bridge Oscillator and determine frequency.

APPARATUS:

Transistor	(BC 107)	2 No
Resistors	10K	4 No
	1 K	3 No
	2.2 K	2 No
	33 K	
	6.8 K	
Capacitors	10	2 No
	100	
	0.01	2 No
RPS	(0 – 30 V)	
Potentiometer		
Bread Boar		
CRO		
Connecting wires		

CIRCUITDIAGRAM:

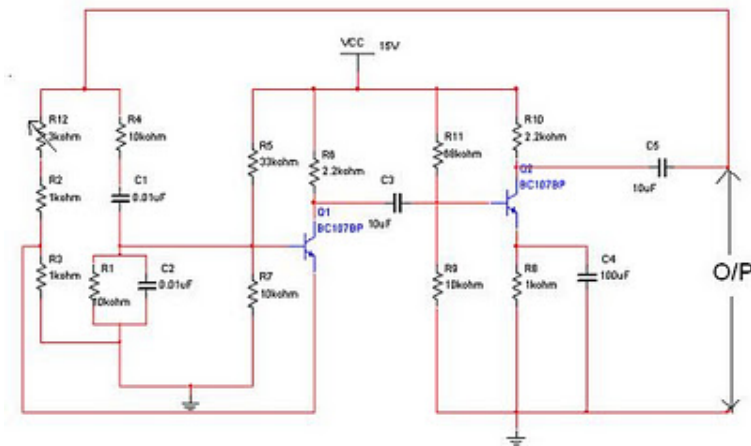

THEORY:

The wein bridge oscillator is a standard circuit for generating low frequencies in the range of 10 Hz to about 1MHz. The method used for getting +ve feedback in wein bridge oscillator is to use two stages of an RC-coupled amplifier. Since one stage of the RC-coupled amplifier introduces a phase shift of 180 deg, two stages will introduces a phase shift of 360 deg. At the frequency of oscillations f the

+ve feedback network shown in fig makes the input & output in the phase. The frequency of oscillations is given as

$$f = 1/2\pi\sqrt{R_1C_1R_2C_2}$$

In addition to the positive feedback

PROCEDURE:

1. Connections are made as per the circuit diagram
2. Feed the output of the oscillator to a C.R.O by making adjustments in the Potentiometer connected in the +ve feedback loop, try to obtain a stable sine Wave.
3. Measure the time period of the waveform obtained on CRO. & calculate the Frequency of oscillations.
4. Repeat the procedure for different values of capacitance.

OBSERVATION:

Given $R=10k\Omega$, $C=0.01\mu F$

$$f_T = 1/2\pi RC$$

$$f_p = \quad =$$

Amplitude, $V_0 =$

MODEL WAVE FORM:

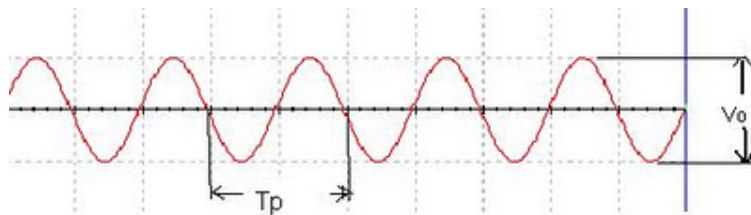

RESULT:

The frequency of the wein bridge oscillator is calculated and is verified